

Enterprise Modelling and Information Systems Architectures

International Journal of Conceptual Modeling

Special Issue: 100 Years of Graphical Business Process Modelling

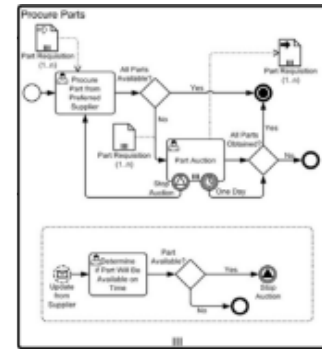

100 years of graphical business process modelling? This sounds like a misprint, but it isn't! On 5-9 December 1921, Frank B. Gilbreth & L. M. Gilbreth presented a new concept named "Process Charts" at the Annual Meeting of The American Society of Mechanical Engineers. They described the notation as "a device for visualizing a process as a means of improving it."

This anniversary is a good opportunity to look back on the past 100 years, to review the present, and to take a view towards the future.

What has been achieved? Which challenges still remain? In a special issue of the EMISA Journal, we invite researchers as well as practitioners to discuss the history, current state and future of business process modelling.

Topics of interest for this special issue include, but are not limited to:

- the history of graphical modelling techniques in general and of business process modelling in particular,
- different approaches to visualize processes,
- suitability of business process models for the communication between business experts, process experts and software experts,
- limits of past and current modelling techniques,
- use of graphical models for analysis and improvement of business processes,
- theories and theoretical approaches to graphical business process modelling,
- challenges such as flexibility, complexity and maintainability,
- automatic business process discovery, analysis and implementation,
- patterns and best practices,
- success and failure stories and conclusions for the future

Guest editors: Ralf Laue, Heinrich Mayr and Bernhard Thalheim

Timescales:

- Intent to submit including abstract: November 1, 2020
(via email to ralf.laue@fh-zwickau.de - You are very invited to discuss suitability and scope of your proposed submission with the guest editors in advance.)
- Full submission of article: December 15, 2020
- First round of reviews completed: April 2021
- Submission of revisions if needed: June 2021
- Second round of reviews completed: August 2021
- Final submission: October 2021
- Publication of Special Issue December 2021

Submissions:

Submissions to this special issue shall follow the journal's author guidelines for general submissions and will be subject to the regular journal review process. For author guidelines and further information on submitting to EMISA, see

<https://www.emisa-journal.org/emisa/about/submissions#authorGuidelines>

Important note: Make sure to enter '100 Years of Graphical Business Process Modelling' in the 'Comments to the editor(s)' text field in step 1 of the online submission process. Also please make sure to select the appropriate type of submission (i.e. 'Original Research Contributions' or 'Experience Reports').

About the EMISA Journal

EMISAJ is a publisher-independent journal, and is published by the German Informatics Society (GI) and is a publication of its SIG on Modelling Business Information Systems (SIG MoBIS) and its SIG on Design Methods for Information Systems

Authors retain copyright and grant the journal 'Enterprise Modelling and Information Systems Architectures - International Journal of Conceptual Modelling' and the Gesellschaft für Informatik e.V. (GI) the permission of first publication, and the non-exclusive, irrevocable and non-time limited publication permission for the submitted work including the permissions to store, copy, distribute and reproduce their work in printed and electronic form for the duration of the legal copyright. This includes the right of translation. Authors grant the journal 'Enterprise Modelling and Information Systems Architectures - International Journal of Conceptual Modelling' and the Gesellschaft für Informatik e.V. (GI) the permission to license their work under a Creative Commons BY-SA 4.0 license that allows others to share the work with an acknowledgement of the work's authorship and initial publication in this journal.

Advantages of publishing in EMISAJ:

International board of renowned editors
Short review cycles with constructive reviews
Long manuscripts accepted for review
Authors remain full copyright
Online publishing with DOI and archiving
Indexed by DBLP, EBSCO and ESCI
Ranked by JOURQUAL and NSD

<https://emisa-journal.org>